

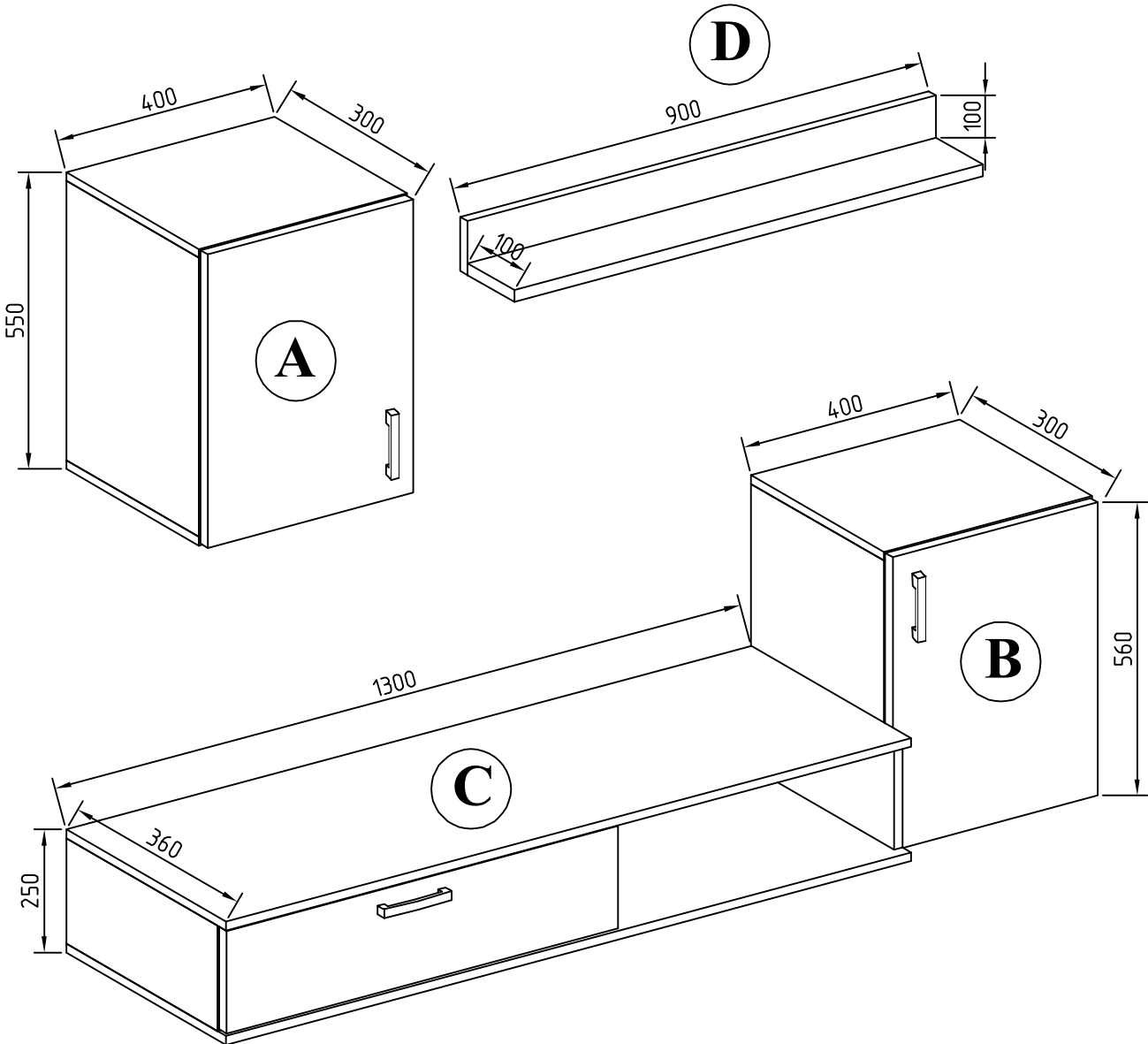

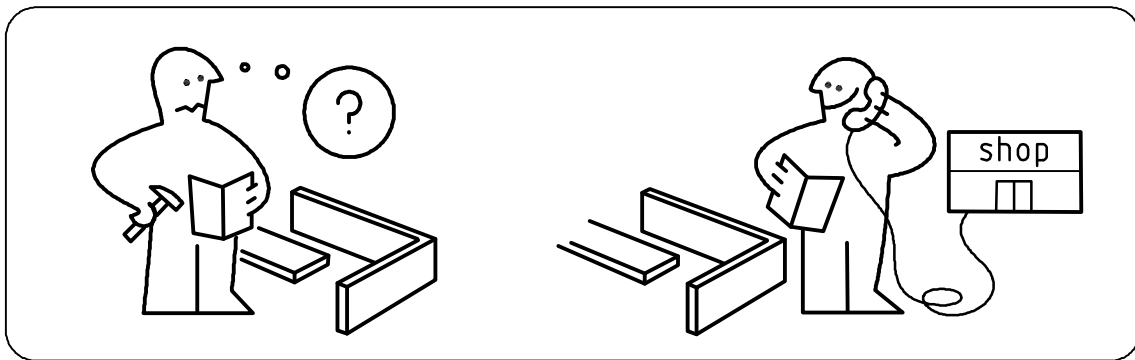

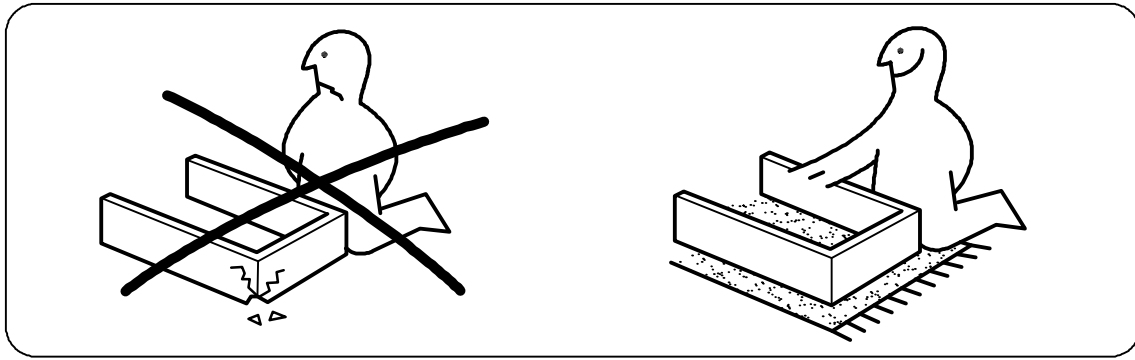

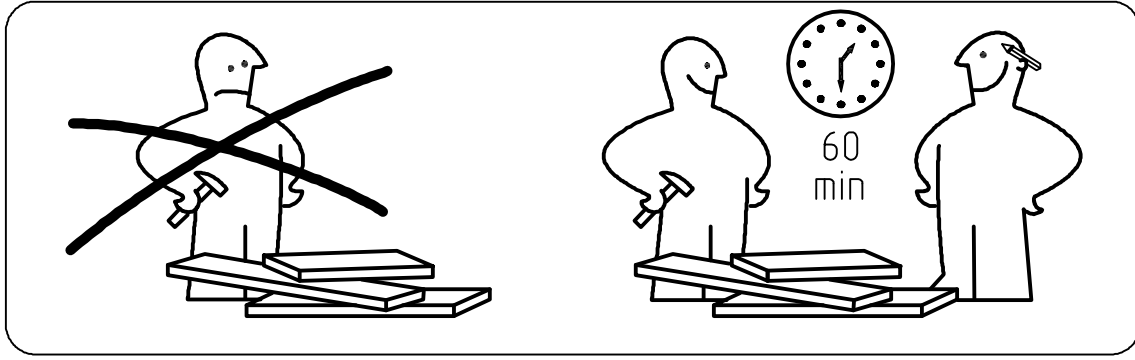

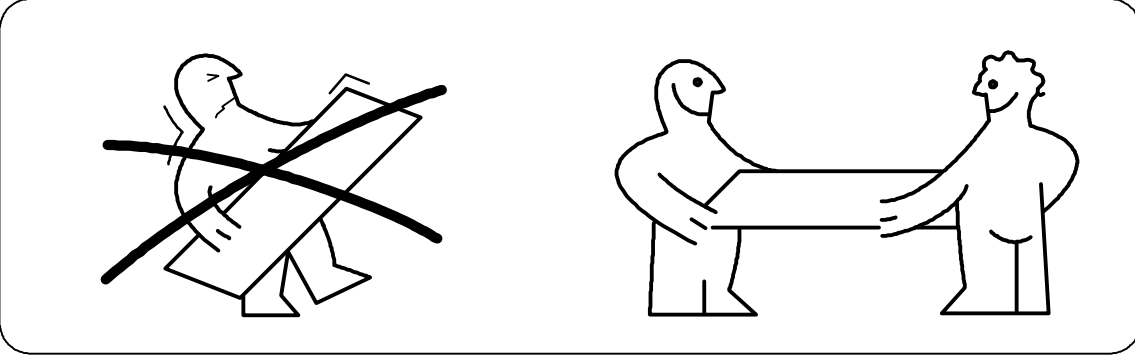
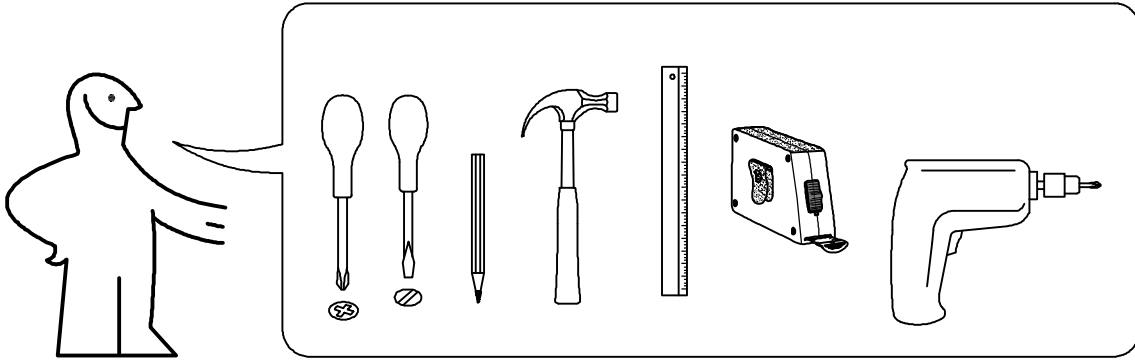





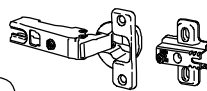
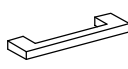

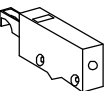
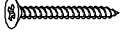

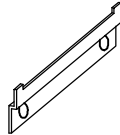
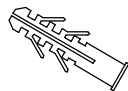

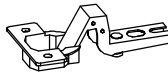
ANIS



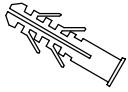

 A1 8*30mm x28	 C1 5*30mm x28	 D1 16mm x28
 D x28	 J1 x8	 F1 6,3*13mm x12
 L1 x4	 I8 x3	 H2 x12
 K5 x9	 N1 x2	 E12 4*30mm x4
 E13 4*40mm x6	 E3 4*16mm x12	 H7 x2
 H5 10*50mm x4	 E16 6*60mm x4	 L3 x2
 N4 L+R x2	 B1 6,3*50mm x5	 B x5
 H4 x2	 H6 8*50mm x2	 E15 4,2*65mm x2
 E4 3*20mm x8	 E5 3,5*16mm x6	

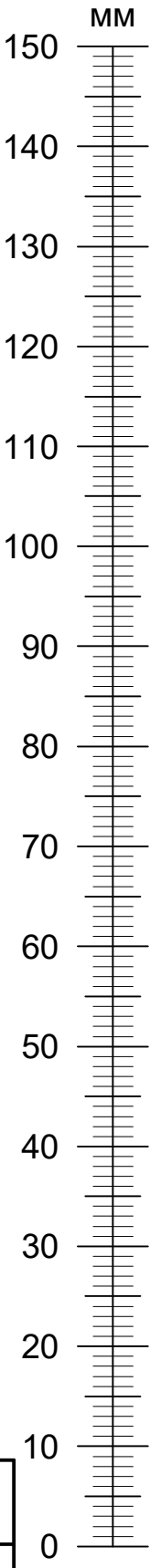

A

B

C

D

No	a*b	x
1	518x284	2
2	400x284	1
3	400x284	1
4	367x260	1
5	394x544	1
6	377x527	1

No	a*b	x
1	518x284	2
2	400x284	1
3	400x284	1
4	367x260	1
5	394x544	1
6	377x527	1

No	a*b	x
1	196x342	2
2	196x328	1
3	1300x360	1
4	1300x360	1
5	752x190	1
6	1277x205	1

No	a*b	x
1	900x100	1
2	900x84	1

