











S1	7x85		x20
S2	7x70		x8
S3	4x30		x20
S4	3,5x20		x16
S5			x4
S6			x2
S7			x4
S8			x20/26/28/30*
S9			x1
S10			x28



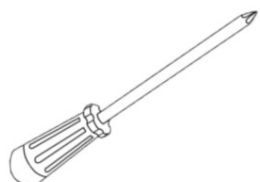
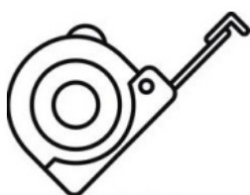
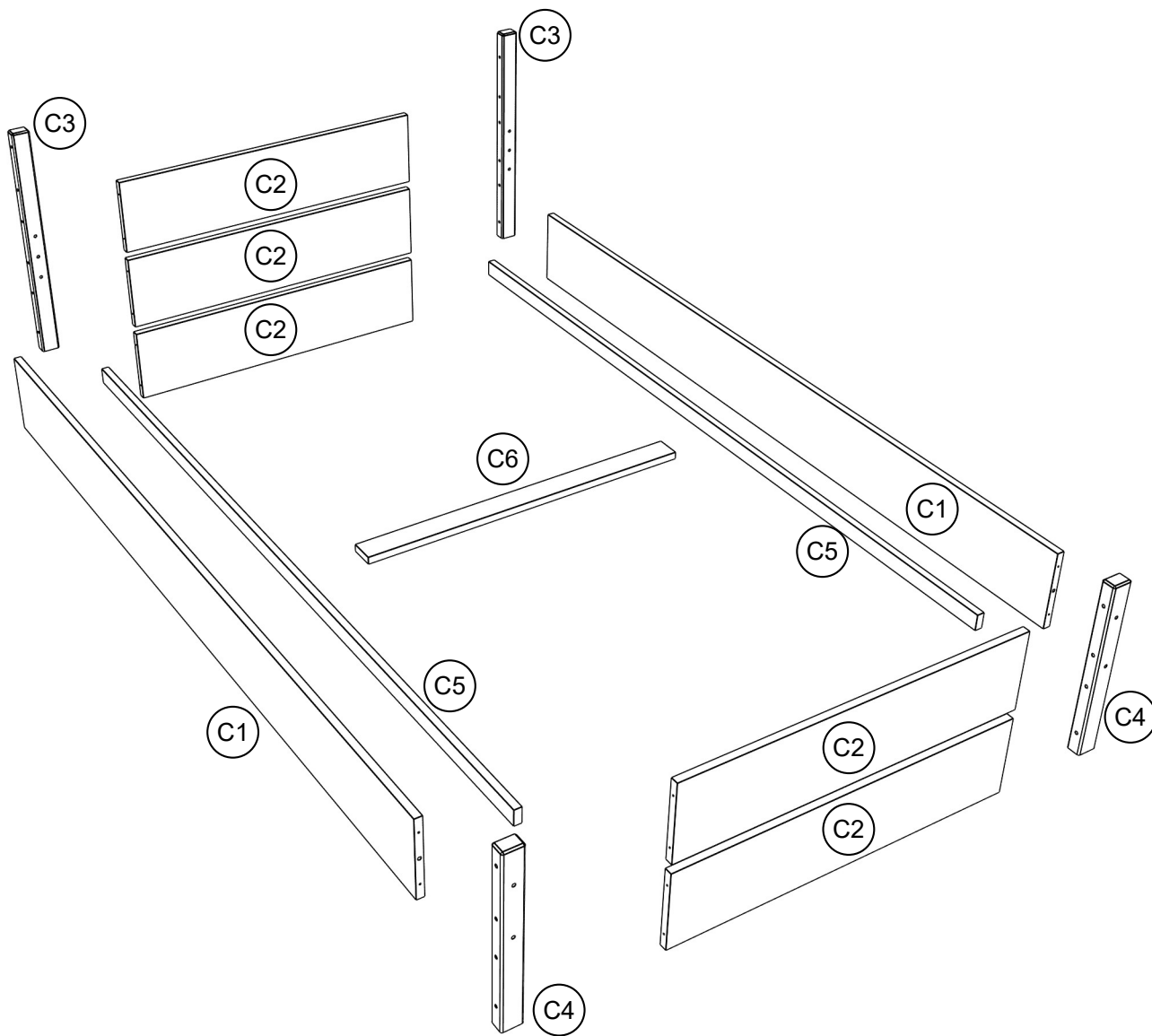

C1	2x
C2	5x
C3	2x
C4	2x
C5	2x
C6	1x

1

S2 x 20

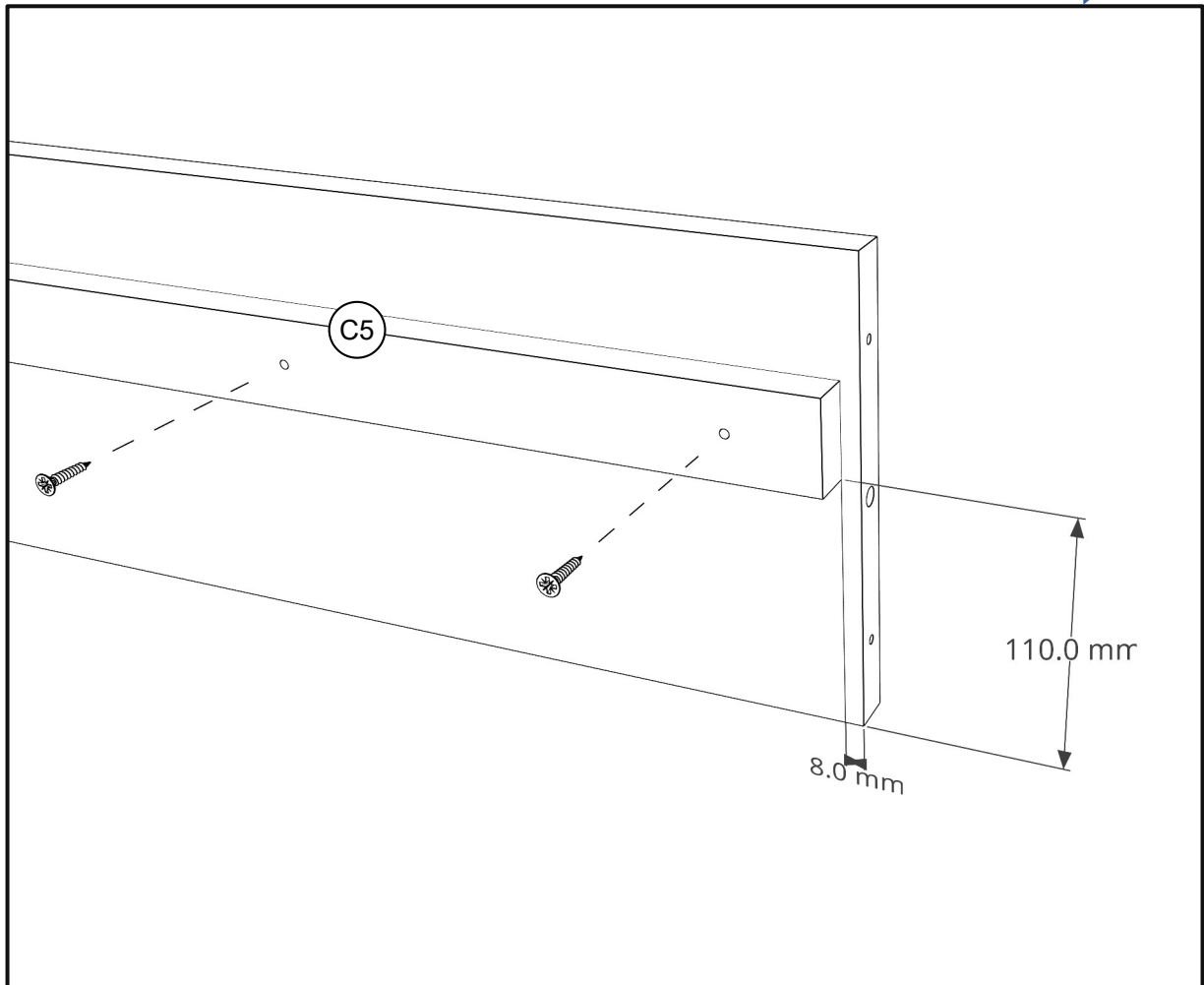
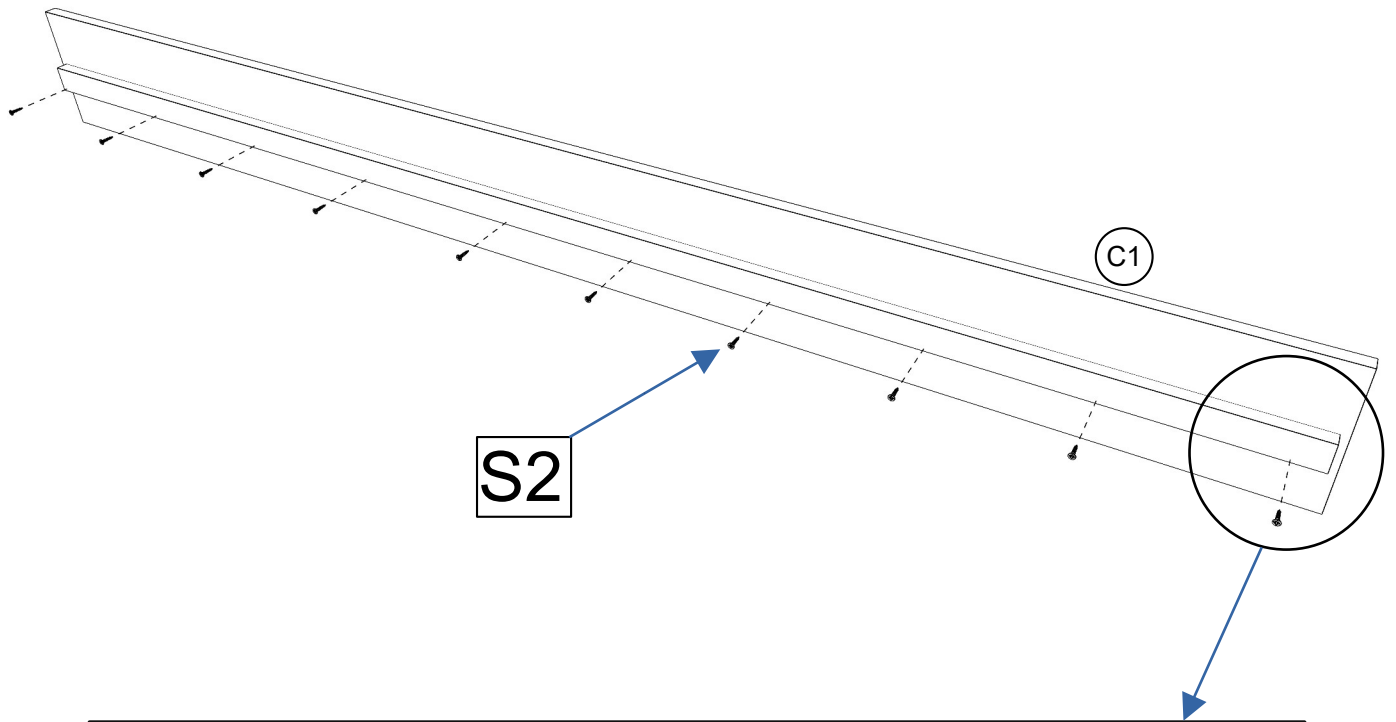

2

S3 x 12 

S5 x 2 

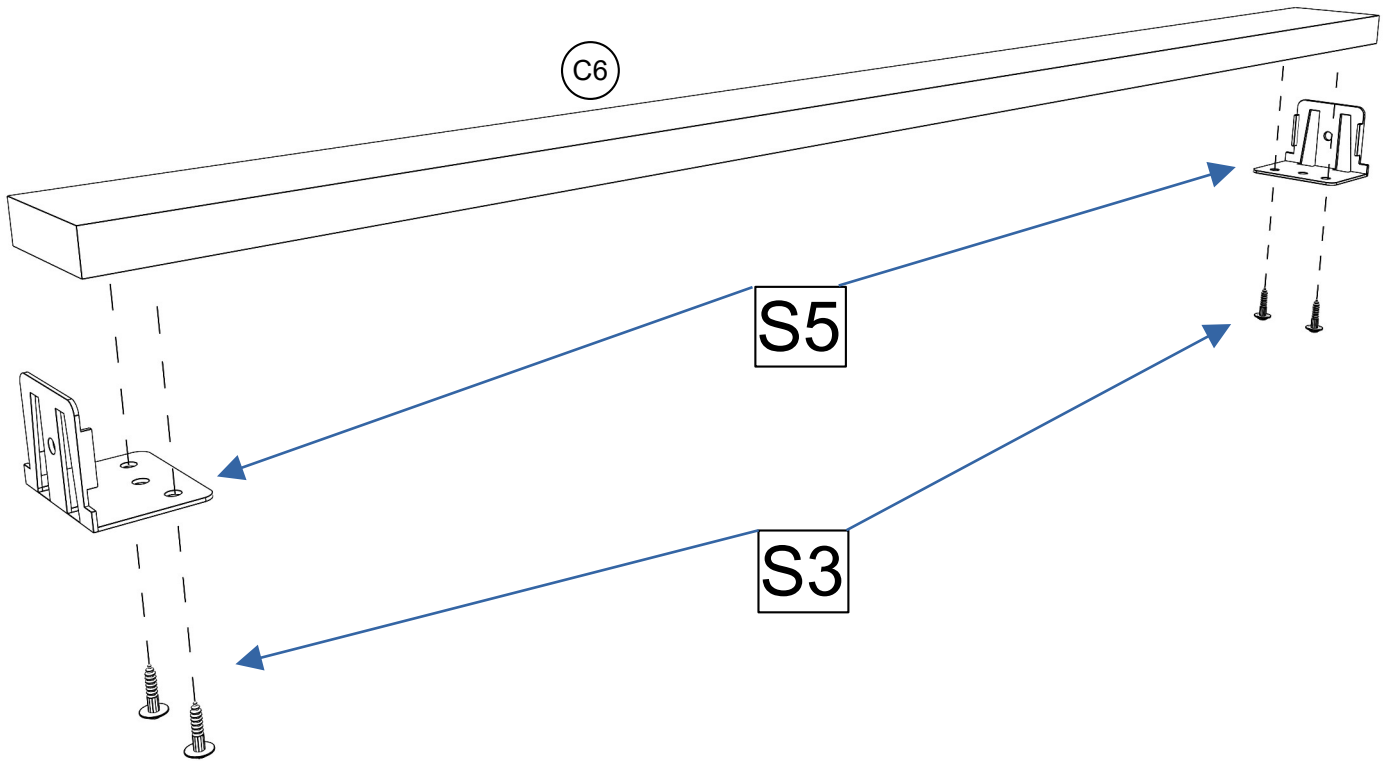
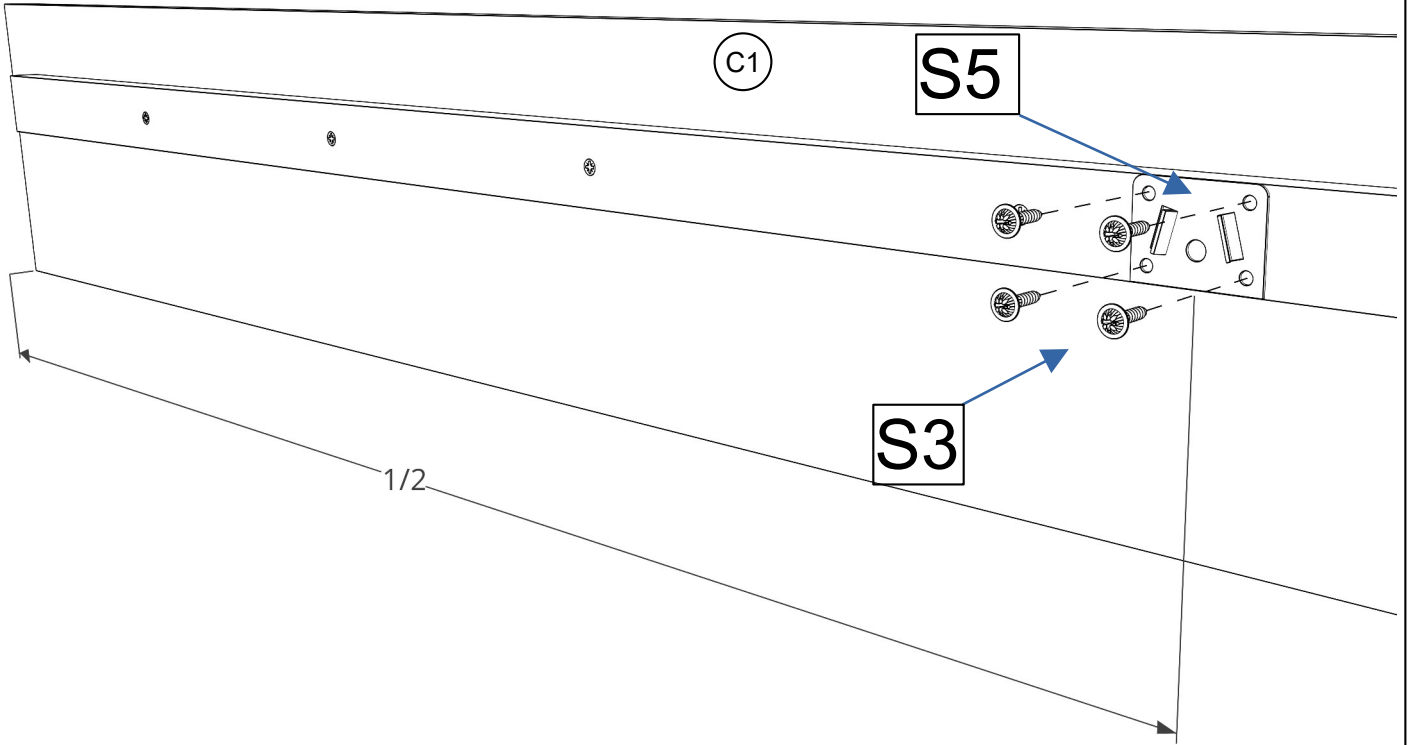

3

S2 x 8



S4 x 4

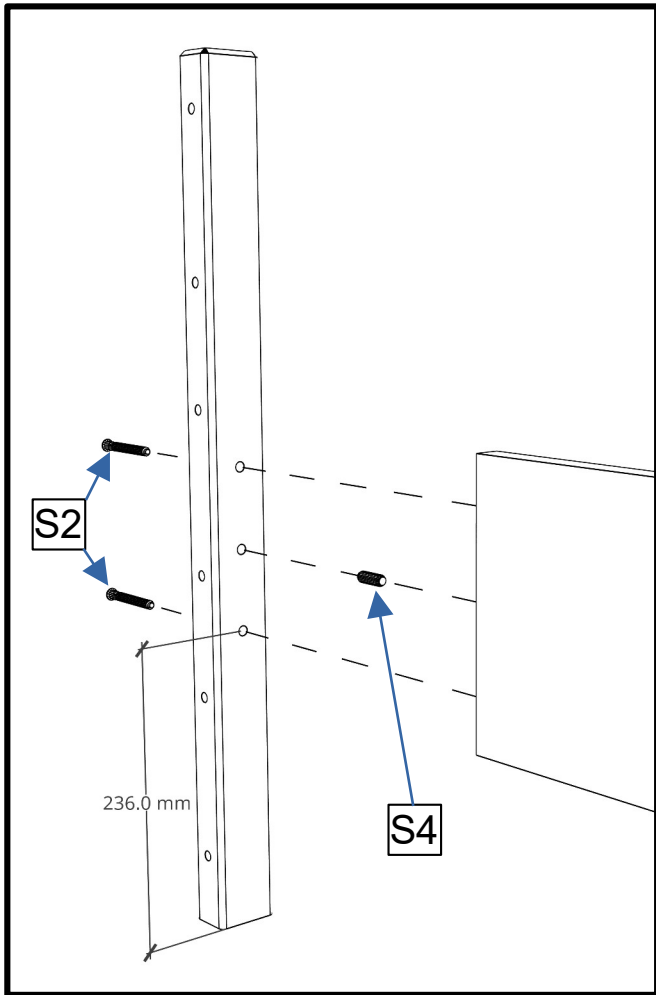
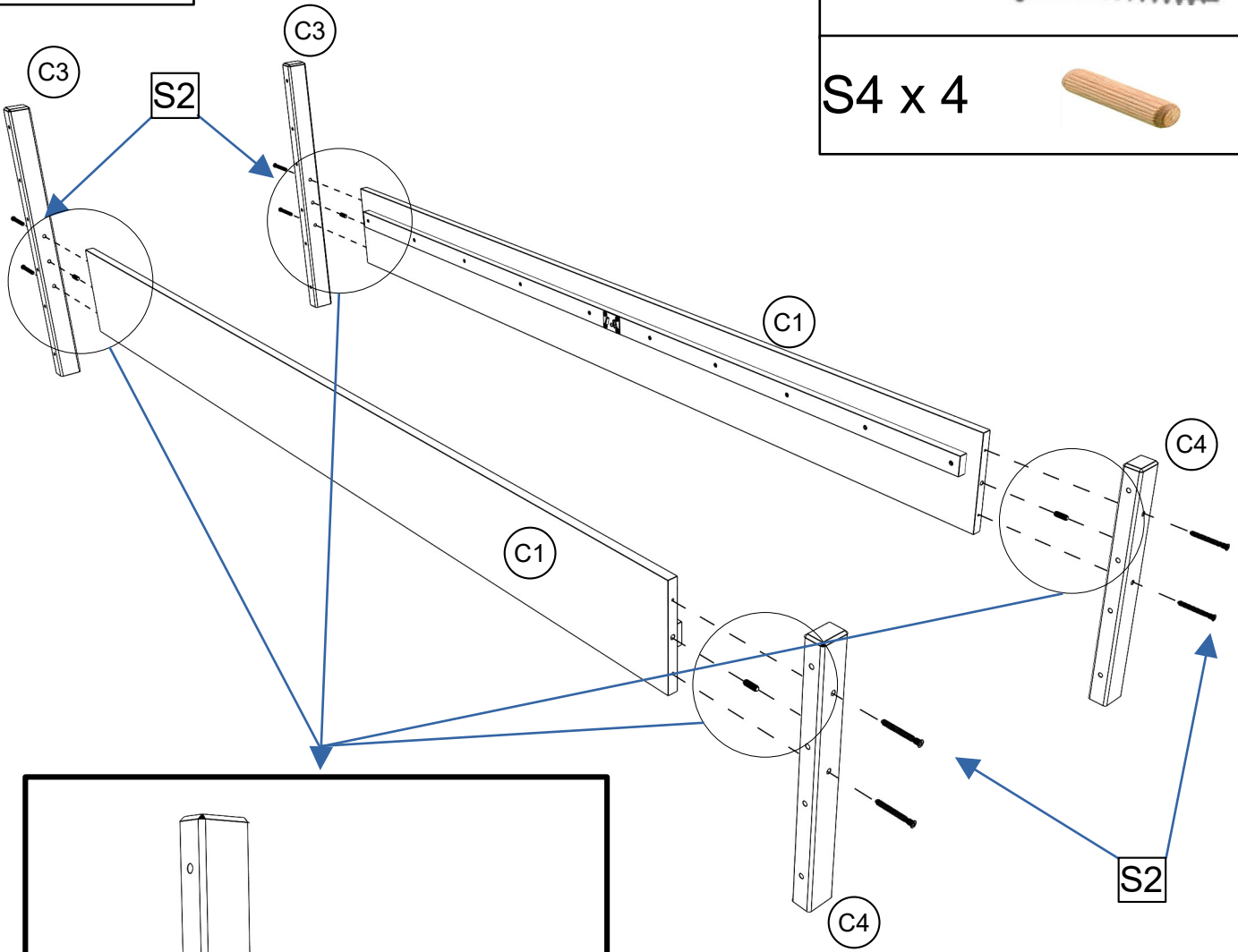

4

S1 x 20 

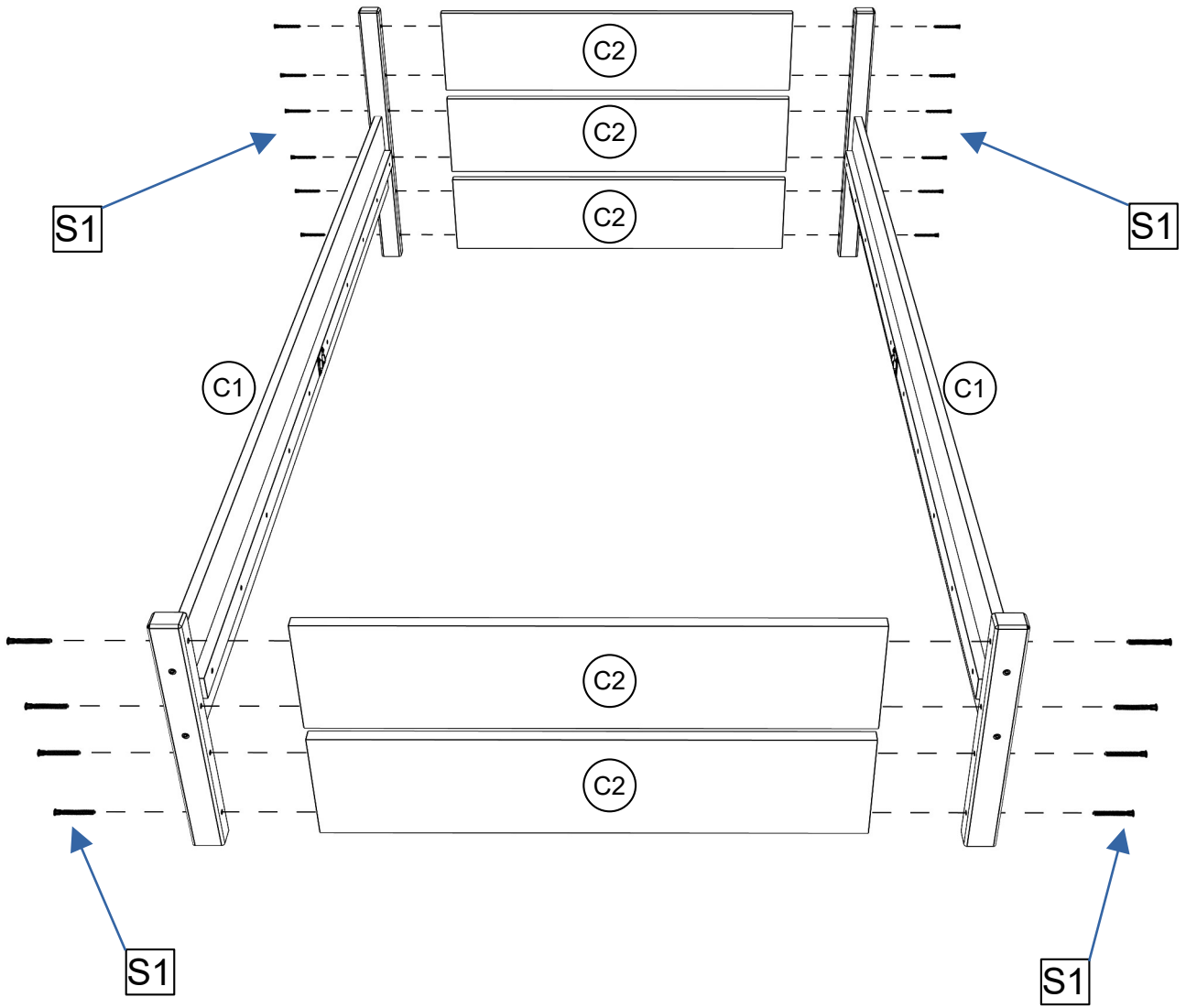

5

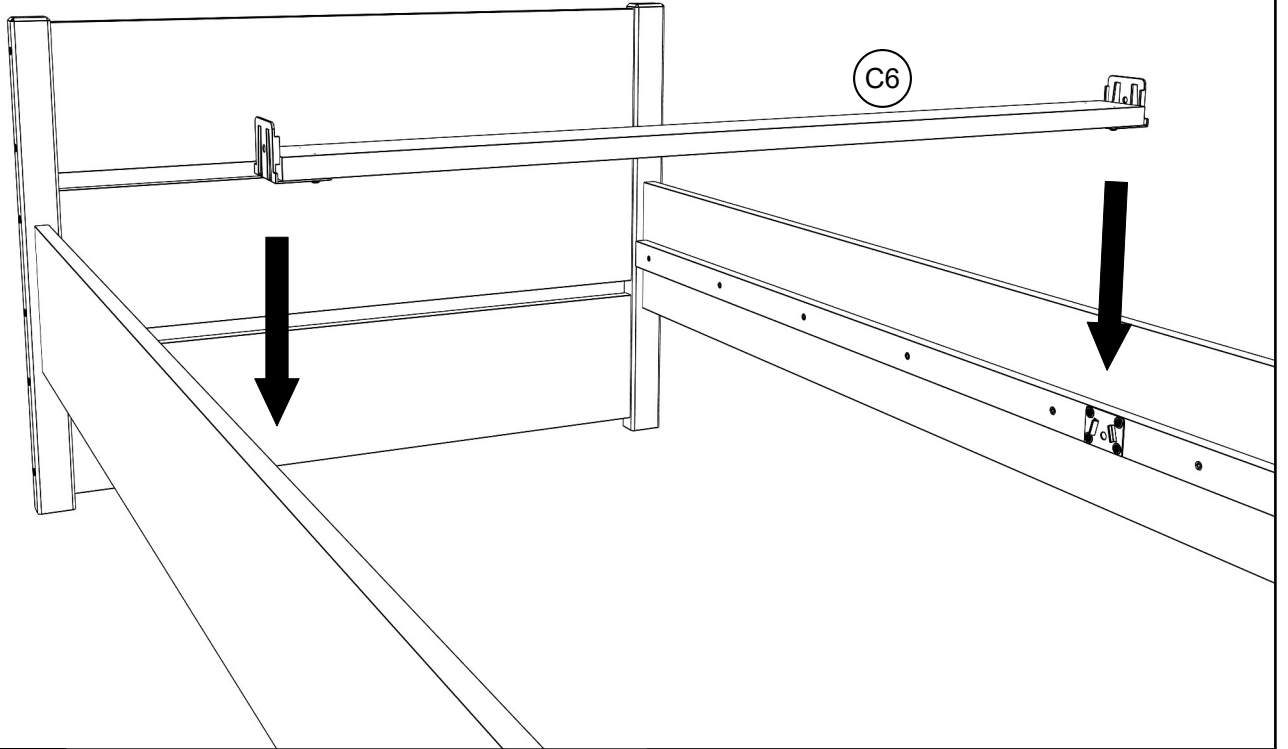

6

S6 x 4



S7 x 20/26/28/30 *



S6

S7

S6

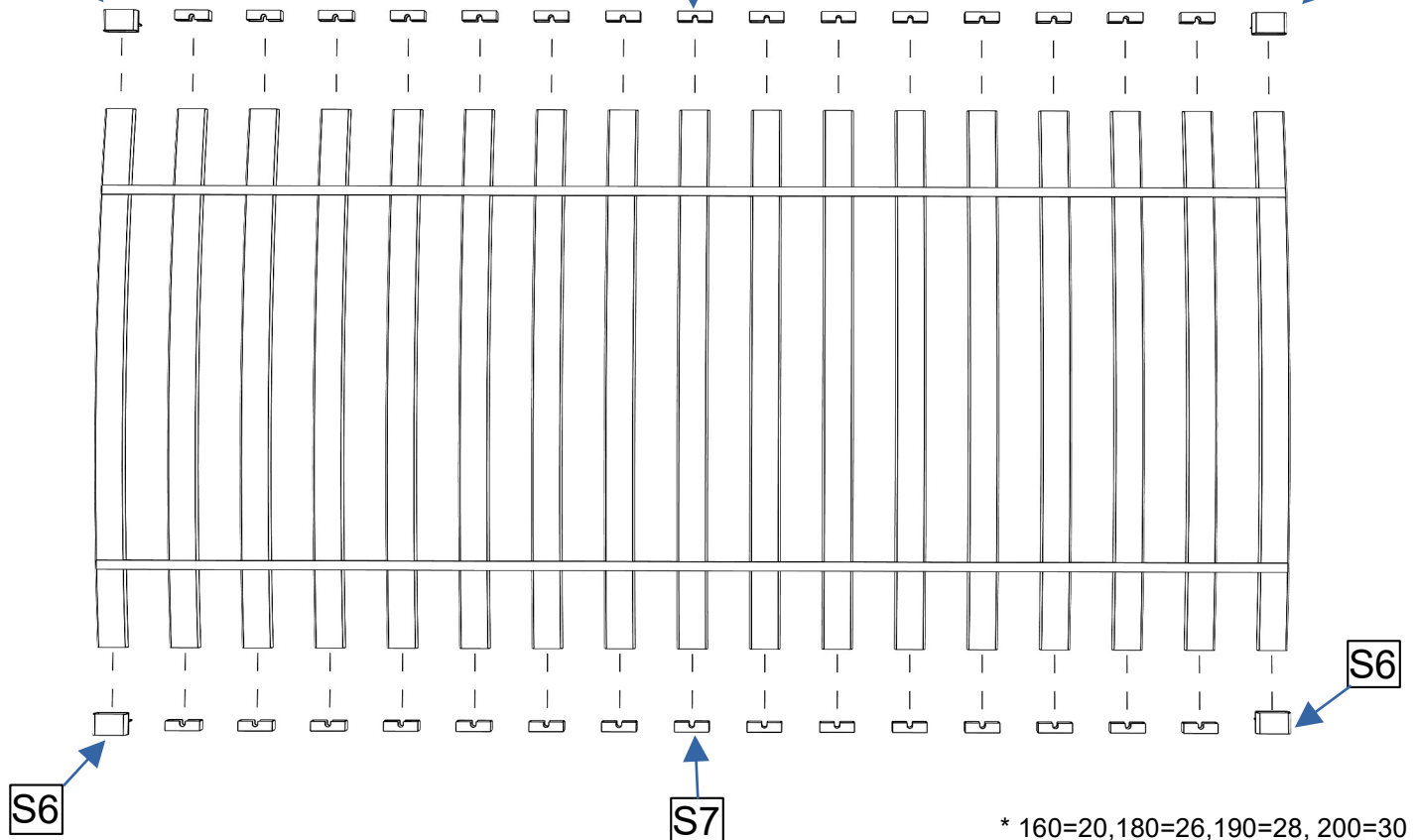

S6

S7

S6

* 160=20,180=26,190=28, 200=30

7

S3 x 4

